

Soft Starter (SMC 3 / SMC 32 two controlled phases)



- Rated operational voltage up to 600 VAC 50/60Hz
- Rated operational current up to 25A/30A
- Output signal for By-Pass and Start/Stop
- Ramp Up and Down time adjustable
- Initial Torque adjustable with kick start
- Wide control voltage range
- Meets EN 60947-4-2 requirements
- High number of start/stop operations pr. hour. See data

Item selection and technical specifications (see also motor table at page 11)

Load ratings	Item number by 208-240VAC 50/60Hz Line Voltage	Item number by 400-480VAC 50/60Hz Line Voltage	Item number by 550-600VAC 50/60Hz Line Voltage	Ramp-Up / Down adjustment	Torque adjustment	Module-width
Items with built-in by-pass relays						
3.5A AC-53b	SMC 3 DA 2303	SMC 3 DA 4003 415V	SMC 3 DA 6003	Ramp-up time 0.5 - 10 sec. Ramp-down time 0.5 - 10 sec.	0- 85% adjustable of nominal torque with selectable kick start 200ms (break loose function)	22.5mm
3.5A AC-53b		SMC 3 DA 4803 480V				22.5mm
15A AC-53b		SMC 32 DA 4015BP 415V*	45mm			
15A AC-53b			45mm			
Items for 100% duty-cycle (AC-53a)						
15A AC-53a	SMC 3 DA 2315	SMC 3 DA 4015		Ramp-up / Ramp down time 0.5 - 20 sec.		45mm
25A AC-53a	SMC 3 DA 2325	SMC 3 DA 4025				90mm
25A AC-53a		SMC 3 DA 4025BP		Ramp-up / Ramp down time 0.5 - 20 sec.		90mm
27A AC-53b w. by-pass		SMC 3 DA 4025BP*				90mm

Output current profile

SMC 3 DA XX03 / SMC 32 DA XX15BP AC-53b	More info. page 45	SMC 3 DA XX25BP AC-53a / AC-53b	More info. page 45
Overload current profile XX03 (with internal by-pass relay)	X-Tx:4-10 : 110	Overload current profile (without by-pass contactor)	X-Tx:6-5 : 100-120
Overload current profile XX15BP (with internal by-pass relay)	X-Tx:8-3 : 110	Overload current profile (with by-pass contactor)	X-Tx:5-5 : 30
Overload relay trip class	10 or 10A	Overload relay trip class	10 or 10A
SMC 3 DA XX15/25 AC-53a	More info. page 45	SMC 3 DA 4025BP	
Overload current profile	X-Tx:8-3 : 100-3000	*Note: External by-pass contactor shall be used for bypassing the soft starter during running by 30A/15kW load @400V.	
Overload relay trip class	10 or 10A		
SMC 3: Leakage current: 5mA ACmax. / Min. operational current: 50mA		SMC 32: Leakage current: 5mA ACmax. / Min. operational current: 50mA	

Control voltage specifications

Control voltage specifications	AC auxiliary contacts / SMC 3 DA XX25BP
Control voltage by line voltage 208-240VAC A1-A2	24 - 230 VAC/DC
Control voltage by line voltage 400-600VAC A1-A2	24 - 480 VAC/DC
Pick-up voltage max.	20.4 VAC/DC
Drop-out voltage min.	5 VAC/DC
Max. control current for no operation	1mA
Response time max.	70msec.
Control current / power max.	15mA / 2VA
Auxiliary specifications:	
Terminal: 13-14, AC SCR Output for start/stop function, Terminal: 23-24, AC SCR Output for connection of by-pass contactor.	
Load specifications: AC SCR: 0.5A AC-14, AC15 24-230/480VAC 50-60Hz Fusing: gl/gG Max i^2t 72A ² S	
General for terminal: 11-12, have no connection with the internal circuit. Can be used in conjunction with a thermal overload protection or for other wiring purposes. See general technical information.	

Common thermal specifications

Power dissipation for continuous operation PDmax	2 W/A without BP	Operation in ambient temperatures exceeding 40°C is possible if the power dissipation is limited either by reducing the steady-state current or by reducing the duty cycle of the soft starter as shown in the table. Max.cycle time 15min. Note: SMC 3 DA XX03 / SMC 32 DA XX15BP see page 45.		
Power dissipation with semiconductor by-passed	4 W Max.			
Cooling method	Natural convection			
Mounting	Vertical +/-30°			
Operating temperature range EN 60947-4-2	-5°C to 40°C			
Max. operating temperature with current derating	60°C			
Storage temperature EN 60947-4-2	-20°C to 80°C			
		By 40°C	By 50°C	By 60°C
		100% load Duty-cycle 100%	80% load Duty-cycle max. 0.8	70% load Duty-cycle max. 0.85

* NOT cUL APPROVED



Soft Starter (SMC 3 / SMC 32 two controlled phases)

Wiring specifications

SMC 3 DA XX03
SMC 32 DA XX15BP

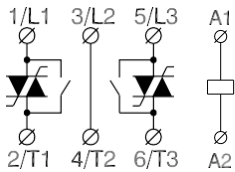

Control voltage A1-A2

SMC 3 DA XX15/25
11-12: for UP62 or other wiring purposes

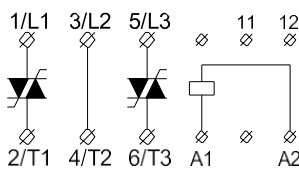

SMC 3 DA XX25 BP

11-12: for UP62 or other wiring purposes

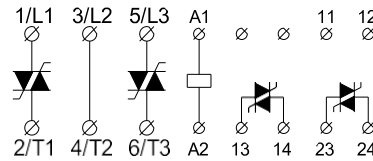

Control voltage A1-A2 Output 13-14: For control of Start/Stop function Output 23-24: By end of ramp up time for by-pass contactor

Wiring example Start/Stop-By-pass (SMC 3 DA XX25 BP)

Auxiliary SCR output contact 13 - 14 (AC voltage only) is used for controlling a Start-Stop function directly wired to the soft starter.
Auxiliary SRC output contact 23-24 (AC voltage only) is activated when the ramp-up time has elapsed. Is used for by-passing the soft starter with an external connected electromechanical contactor.

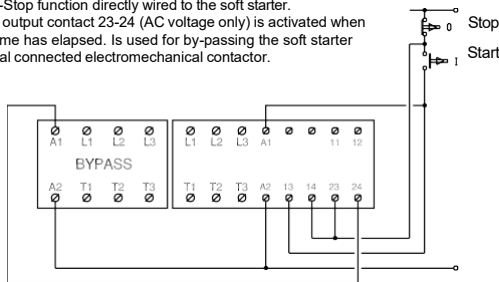

Motor wiring with or without by-pass (SMC 3 DA XX25 BP)

Standard wiring of a softstarter to a 3-phase motor in delta configuration.

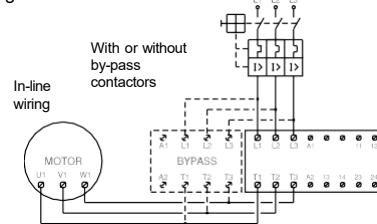

*Use UL approved Magnetic Circuit Breaker or UL specified back-up fuse type K5 or H Class

Short-circuit protection by circuit breaker or fuses

Two type of short-circuit protection can be used:

- Short-circuit protection by circuit breaker.
- Short-circuit protection by fuses.

Short-circuit protection is divided into 2 levels Type 1 or Type 2

Co-ordination Type 1: Short-circuit protects the installation

Co-ordination Type 2: Short-circuit protects the installation and the semi-conductors inside the motor controller

a) Short-circuit protection

Co-ordination type 1 will be obtained when using magnetic circuit breakers or standard gI/GI fuses.

Co-ordination type 2 will be obtained when using semiconductor fuses. When using semiconductor fuses the SCR will not be damaged due to transients and short circuits. The table indicates suitable fuses for co-ordination type 2 protection.

b) Short-circuit protection by fuses

Type 1: SMC 3 DA XX03	Protection max. 25 A. gL/gG
Type 1: SMC 32 DA XX15 BP	Protection max. 50 A. gL/gG 63A T
Type 1: SMC 3 DA XX15	Protection max. 50 A. gL/gG 63A T
Type 1: SMC 3 DA XX25	Protection max. 80 A. gL/gG 63A T
Type 1: SMC 3 DA XX25 BP	Protection max. 80 A. gL/gG 63A T

Type 2: SMC 3 DA XX03	Protection max. i^2t of the fuse 72 A ² S
Type 2: SMC 32 DA XX15 BP	Protection max. i^2t of the fuse 1800 A ² S
Type 2: SMC 3 DA XX15	Protection max. i^2t of the fuse 1800 A ² S
Type 2: SMC 3 DA XX25	Protection max. i^2t of the fuse 6300 A ² S
Type 2: SMC 3 DA XX25 BP	Protection max. i^2t of the fuse 6300 A ² S

Fuses from e.g. Ferraz, Siba, Bussmann can be used as short-circuit protection Type 2

More information concerning Co-ordination Type 2 see page 45

Approval

cUL Std No. 508 (Not approved SMC 32 DA XX15BP)

Application, adjustment hints and general specifications

See page 10-11 / 44-45

Dimensions (see also page 44)

Type	H	D	W
22.5 mm module	94 mm	123.8 mm	22.5 mm
45 mm module	94 mm	128.1 mm	45 mm
90 mm module	94 mm	128.1 mm	90 mm

Soft Starter (SMC 33 / three controlled phases)



- Rated operational voltage up to 480 VAC 50/60Hz
- Rated operational current up to 86A (inside delta DBP)
- Output signal for By-Pass and Start/Stop
- Ramp Up and Down time adjustable
- Initial Torque adjustable with kick start
- Wide control voltage range
- Meets EN 60947-4-2 requirements
- High number of start/stop operations pr. hour. See data.

Item selection and technical specifications (see also motor table at page 11)

Load ratings	Item number by 208-240VAC 50/60Hz Line Voltage	Item number by 400-480VAC 50/60Hz Line Voltage	Item number by 550-600VAC 50/60Hz Line Voltage	Ramp-Up / Down adjustment	Torque adjustment	Module-width
¹ Inside delta configuration						
15A AC-53a		SMC 33 DA 4015				90 mm
15A AC-53a no by-pass		SMC 33 DA 4025BP				90 mm
27A AC-53b w. by-pass		SMC 33 DA 4025BP				90 mm
* 35A AC-53a no by-pass	SMC 33 DA 2350BP*	SMC 33 DA 4050BP*		Ramp-up time 0.5 - 30 sec.	0- 85% adjustable of nominal torque with selectable kick start 200ms (break loose function)	180 mm
* 50A AC-53b w. by-pass	SMC 33 DA 2350BP*	SMC 33 DA 4050BP*				180 mm
Items for Inside delta configuration				Ramp-down time 0.5 - 60 sec.		90 mm
¹ 25A AC-53a no by-pass		SMC 33 DA 4040DBP				90 mm
¹ 43A AC-53b w. by-pass		SMC 33 DA 4040DBP			180 mm	
* ¹ 60A AC-53a no by-pass	SMC 33 DA 2385DBP*	SMC 33 DA 4085DBP*			180 mm	
* ¹ 86A AC-53b w. by-pass	SMC 33 DA 2385DBP*	SMC 33 DA 4085DBP*			180 mm	

Load specified with utilisation category AC-53a

SMC 33 DA XXXX BP AC-53a: No by-pass contactors is necessary during running, shall be connected as inline configuration

SMC 33 DA XXXX DBP AC-53a: No by-pass contactors is necessary but motor shall be connected in an inside-delta configuration

Load specified with utilisation category AC53b

SMC 33 DA XXXX BP AC-53b: By-pass contactor shall be used for bypassing the soft starter during running, shall be connected as inline configuration

SMC 33 DA XXXX DBP AC-53b: By-pass contactor shall be used and motor connected in an inside-delta configuration

Output load specification (90mm module) more info page 45

Overload current profile AC-53a (without by-pass contactor)	X-Tx:6-5 : 100-120
Overload current profile AC-53b (with by-pass contactor)	X-Tx:5-5 : 30
Overload relay trip class AC-53a/AC53b	10 or 10A

Leakage current: 5mA ACmax. | Min. operational current: 50mA

Output load specification (180mm module) more info page 45

Overload current profile AC-53a (without by-pass contactor)	X-Tx:6-6 : 100-120
Overload current profile AC-53b (with by-pass contactor)	X-Tx:6-6 : 30
Overload relay trip class AC-53a/AC53b	10 or 10A

Leakage current: 5mA ACmax. | Min. operational current: 50mA

Control terminal specifications

Control voltage by line voltage 208-240VAC A1-A2	24 - 230 VAC/DC
Control voltage by line voltage 400-600VAC A1-A2	24 - 480 VAC/DC
Pick-up voltage max.	20.4 VAC/DC
Drop-out voltage min.	5 VAC/DC
Max. control current for no operation	1mA
Response time max.	70msec.
Control current / power max.	15mA / 2VA

Auxiliary contacts

Terminal: 13-14, AC SCR output for start/stop function,
Terminal: 23-24, AC SCR output for connection of by-pass contactor.

Output specifications for 90mm module: AC SCR: 0.5A AC-14, AC15 24-230/480V AC 50-60Hz Fusing: gI/gG Max i^2t 72A²S

Output specifications for 180mm module: AC SCR: 1.0A AC-14, AC15 24-230/480V AC 50-60Hz Fusing: gI/gG Max i^2t 72A²S

Terminal: 11-12, have no connection with the internal circuit. Can be used in conjunction with a thermal overload protection or for other wiring purposes. See under general technical information.

Thermal specification

Power dissipation for continuous operation PDmax	3 W/A without BP
Power dissipation with semiconductor by-passed	5 W Max. with BP
Cooling method	Natural convection
Mounting	Vertical +/- 30°
Operating temperature range EN 60947-4-2	-5°C to 40°C
Max. operating temperature with current derating	60°C
Storage temperature EN 60947-4-2	-20°C to 80°C

Operation in ambient temperatures exceeding 40°C is possible if the power dissipation is limited either by reducing the steady-state current or by reducing the duty-cycle of the soft starter as shown in the table. Max. cycle time 15min.

By 40°C	By 50°C	By 60°C
100% load Duty-cycle 100%	80% load Duty-cycle max. 0.8	70% load Duty-cycle max. 0,65

* NOT cUL APPROVED

Specifications are subject to change without notice

Soft Starter (SMC 33 / three controlled phases)

Wiring specifications (90mm module)

For wiring purposes

Output 23-24:
By end of ramp up time
for by-pass contactor
Do not include SMC 33 DA XX15

Stop function
Do not include SMC 33 DA XX15

Wiring specifications (180mm module)

11-12: for UP62 or other wiring purposes

Output 13-14:
For control of Start/ Stop function

Control voltage A1-A2

Output 23-24:
By end of ramp up time
for by-pass contactor

Wiring information: Delta configuration

3-pole
Breaker
Type 3
Class

Wiring information: Inside-delta configuration

3-pole
Breaker
Type 3
Class

Wiring example Start/Stop - By-pass (90 mm modul)

Auxiliary SCR output contact 13-14 (AC voltage only) is used for controlling a Start-Stop function directly wired to the soft starter.
Auxiliary SRC output contact 23-24 (AC voltage only) is activated when the ramp-up time has elapsed. Is used for by-passing the soft starter with an external connected electromechanical contactor.

Wiring example Start/Stop - By-pass (180 mm modul)

Auxiliary SCR controlling a Start-Stop function directly wired to the soft starter.
Auxiliary SRC output contact 23-24 (AC voltage only) is activated when the ramp-up time has elapsed. Is used for by-passing the soft starter with an external connected electromechanical contactor.

Short-circuit protection by circuit breaker or fuses

Two type of short-circuit protection can be used:
a) Short-circuit protection by circuit breaker.
b) Short-circuit protection by fuses.

Short-circuit protection is divided into 2 levels **Type 1 or Type 2**

Co-ordination Type1: Short-circuit protects the installation

Co-ordination Type 2: Short-circuit protects the installation and the semi-conductors inside the motor controller

a) Short-circuit protection	
Co-ordination type 1 will be obtained when using magnetic circuit breakers or standard gL/GI fuses.	
Co-ordination type 2 will be obtained when using semiconductor fuses. When using semiconductor fuses the SCR will not be damaged due to transients and short circuits. The table indicates suitable fuses for co-ordination type 2 protection.	

b) Short-circuit protection by fuses	
Type 1: SMC 33 DA XX15	Protection max. 50 A gL/gG
Type 1: SMC 33 DA XX25 BP	Protection max. 80 A gL/gG
Type 1: SMC 33 DA XX40 DBP	Protection max. 80 A gL/gG
Type 1: SMC 33 DA XX50 BP	Protection max. 125 A gL/gG
Type 1: SMC 33 DA XX85 DBP	Protection max. 125 A gL/gG
Type 2: SMC 33 DA XX15	Protection max. i^2t of the fuse 1800 A ² S
Type 2: SMC 33 DA XX25 BP	Protection max. i^2t of the fuse 6300 A ² S
Type 2: SMC 33 DA XX40 DBP	Protection max. i^2t of the fuse 6300 A ² S
Type 2: SMC 33 DA XX50 BP	Protection max. i^2t of the fuse 25300 A ² S
Type 2: SMC 33 DA XX85 DBP	Protection max. i^2t of the fuse 25300 A ² S

Fuses from e.g. Ferraz, Siba, Bussmann can be used as short-circuit protection Type 2

More information concerning Co-ordination Type 2 see page 45

Approval

cUL Std No. 508 (Not approved SMC 33 DA XX50BP and SMC 33 DA XX85DBP)

Application, adjustment hints and general specifications

See page 10-11 / 44-45



3-Phase electronic motor contactor (Direct On Line)



- For Direct On Line start of 3 phase motors
- Rated operational voltage up to 600 VAC 50/60 Hz
- Rated operational current up to 15A AC-3
- Versatile control circuit: 24-480VAC / 24-60VDC
- Unlimited number of start/stop operations / hour
- LED Status indication
- Meets EN 60947-4-2 requirements
- Requires only 45 mm DIN rail space

Item selection and technical specifications					
Load ratings AC-53 motor load stand. AC-4 motor load inching / plugging	Control voltage	Item number by 208-240VAC 50/60Hz Line Voltage	Item number by 400-480VAC 50/60Hz Line Voltage	Item number by 550-600VAC 50/60Hz Line Voltage	Module-width
15A AC-53	24-60VDC / 24-480VAC		SMC 3 DA 4015 DOL		45mm
Output load specification					
Operational current AC-53	15A	Min. operational current	50mA		
Leakage current	5mA ACmax.	Duty cycle	100%		
Control terminal specifications					
Control voltage	24-60 VDC/24-480 VAC	Control current / power max.	6mA / 1.5 VA		
Pick-up voltage max.	20.4 VAC / DC	Max. control voltage	510 VAC		
Drop-out voltage min.	5 VAC / DC	Response time max.	1 cycle		
Thermal specification					
Power dissipation for continuous operation PDmax	2.2 W/A	Operation in ambient temperatures exceeding 40°C is possible if the power dissipation is limited either by reducing the steady-state current or by reducing the duty-cycle of the soft starter as shown in the table.			
Power dissipation for intermittent operation PD	2.2 W/A x dutycycle				
Cooling method	Natural convection				
Mounting	Vertical +/-30°				
Operating temperature range EN 60947-4-2	-5C° to 40°C				
Storage temperature EN 60947-4-2	-20C° to 80°C				
Max. operating temperature with current derating	60°C				
Insulation specifications					
Rated insulation voltage	Ui 660 Volt				
Rated impulse withstand voltage	Uimp. 4 kVolt				
Installation category	III				
Utilisation Categories EN60947-4-2					
Category AC - 53	Starting, switching off motors during running.	Approval			
Category AC - 4	Starting, plugging, reversing the motor rapidly while the motor is running.	ULc Std No. 508 / CAN/CSA-C22.2			
Category AC - 52a	Control of slipring motor stators	Mounting and cable wiring information			
Category AC - 53a	Control of squirrel cage motor	Mounting information see page 36 / Cable wiring see page 37			
Category AC - 58a	Control of hermetic refrigerant compressors with automatic resetting of overload releases	Dimensions (se also page 36)			
		Type	H	D	W
		45 mm module	94 mm	128.1 mm	45 mm
EMC					
This component meets the requirements of the product standard EN60947-4-2 and is CE marked according to this standard.					



3-Phase electronic motor contactor (Direct On Line)

Wiring specifications

SMC 3 DA XX15 DOL

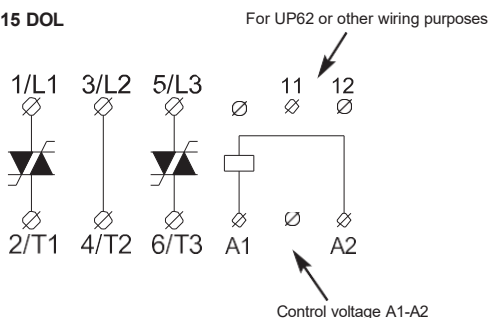

Short-circuit protection by circuit breaker or fuses

Two type of short-circuit protection can be used:

- Short-circuit protection by circuit breaker.
- Short-circuit protection by fuses.

Short-circuit protection is divided into 2 levels **Type 1** or **Type 2**

Co-ordination Type 1: Short-circuit protects the installation

Co-ordination Type 2: Short-circuit protects the installation and the semiconductors inside the motor controller

a) Short-circuit protection by circuit breaker

A 3-Phase motor with correctly installed and adjusted overload relay will not short circuit totally to earth or between the 3 phases. Part of the winding will normally limit the short circuit current to a value that will cause instantaneous magnetic tripping of the circuit breaker without damage to the electronic contactor. The magnetic trip response current is approx. 11 times the max. adjustable current.

b) Short-circuit protection by fuses

Type 1: SMC 3 DA XX15 DOL Protection max. 50 A gL/gG

Type 2: SMC 3 DA XX15 DOL Protection max. I_{2t} of the fuse 1800 A₂S

Fuses from e.g. Ferraz, Siba, Bussmann can be used as short-circuit protection Type 2

More information concerning Co-ordination Type 2 see page 37

Overload Protection in Motor Control Reversing

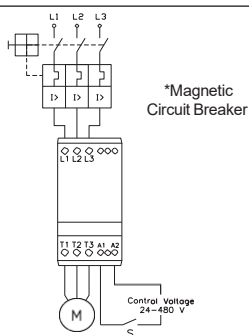

Overload protection of the motor is easily achieved by installing a manual thermal magnetic circuit breaker on the supply side of the motor.

The circuit breaker provides means for padlocking and the necessary clearance for use as a circuit isolator according to EN 60204-1.

Adjust the current limit on the MCB according to the rated nominal current of the motor

*Use UL approved Magnetic Circuit Breaker or UL specified back-up fuse type K5 or H Class

Thermal overload protection (see also page 36)

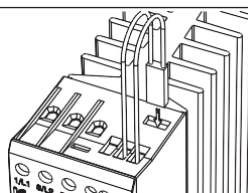

Optional thermal overload protection is possible by inserting a thermostat in a slot on the right hand side of the soft starter. Type number UP62

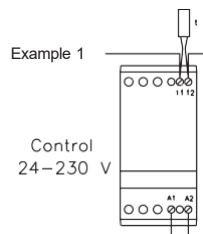

The thermostat can be connected in series with the control circuit of the soft starter. When the temperature of the heatsink exceeds 90°C the soft starter will switch Off.

Note: When the temperature has dropped approx. 30°C the soft starter will automatically be switched on again.

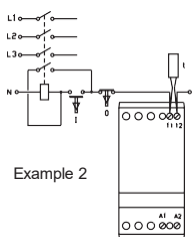

The thermostat is connected in series with the control circuit of the main contactor.

When the temperature of the heatsink exceeds 90°C the main contactor will switch Off. A manual reset is necessary to restart this circuit.

SMC 3 DOL General application information

The SMC 3 DOL has been developed for cranes and other harsh applications where inching, jogging and plugging is frequently used and where a high number of operating cycles are essential. In such applications the lifetime of the equipment is normally limited by the short lifetime of the electromechanical contactor. Electromechanical contactors are not designed to switch off motors in locked rotor- or overload conditions where the current is 6 times the nominal operational current (AC-4). The severe arcing will burn the contact elements resulting in unreliable contact function. The Semiconductor Contactor will close the contacts in the zero crossing of the mains voltage and switch-Off will always occur in the zero crossing of the motor current in this way voltage kickback from the inductive motor windings is avoided. The lifetime, therefore, of the Semiconductoc Contactor will always be at least one decade longer than the electromechanical contactor.

Comparison of lifetime in different utilization categories

Utilization-categories	Typical applications	Electro-mechanical Contactor	Semiconductor Contactors SMC3DA...DOL
AC-52a	Control of slip-ring motors, starting, switching Off	0.7 Mill. Cycles	25 Mill. Cycles
AC-53a	Control of squirrel-cage motors, starting, switching Off	1.3 Mill. Cycles	25 Mill. Cycles
AC-4	Control of squirrel-cage motors, starting, plugging, inching	0.06 Mill. Cycles	5 Mill. Cycles